

MicaSense RedEdge-P™ and DLS 2 Integration Guide



Revision 01

July 2022 upload



Seattle, WA

Table of Contents

Introduction	3
Firmware	3
What's Included?	3
Lens and Imager Information	4
Center wavelengths and bandwidth	4
Imager/band number and output	5
Measurements and Attachment Points	5
Recommendations for Installation	6
Input and Output	8
External Power ("PWR")	9
Power supply specifications	9
Power Input	9
DLS connector	10
Serial and Ethernet Data ("COMM")	11
GPIO pins	11
IO Pin voltage	12
Breakout board	12
LED indicators	13
USB port	13
Capture Rate	13
Automatic Capture/Triggering	14
Overlap (recommended)	14
Timer	14
External Triggering	14
External Trigger	15
HTTP API (Ethernet and Wi-Fi)	15
Serial API	15

Disabled	16
Configuration Examples	17
Default + Overlap mode	17
Default + Trigger by HTTP API	17
MAVLink with PixHawk or similar flight controller	17
DLS 2 with Aircraft GPS	18
Downwelling Light Sensor 2 (DLS 2)	19
Measurements and Attachment Points	19
DLS 2 Connectors and Buttons	20
DLS 2 Installation Guidelines	22
Fixed wing	22
Multirotor	22
Example integration photo	23

Introduction

MicaSense RedEdge-P provides multiple options for integration - from stand-alone (where only power is provided to the sensor) to fully customized integrations. Advanced integrations take advantage of flexible interfaces including ethernet, serial, and PWM/GPIO trigger, for seamless integration with any aircraft.

Firmware

It is important to have the latest version of firmware installed on the RedEdge-P. Please see the following page to get the latest version and learn how to update the sensor's firmware:

<https://www.micasense.com/firmware-updates>

What's Included?

- RedEdge-P sensor
- DLS 2 sensor
- Calibrated Reflectance Panel ("CRP 2")
- Edimax Wi-Fi adapter
- CFexpress card
- CFexpress card reader
- COMM cable (15-pin)
- Power cable (4-pin)
- 60 cm DLS 2 connector cable (6-pin)
- Hard carrying case
- Lens cover (opaque - not for use during operation)
- M3 x 10mm screws, washers (QTY 4)
- M2 x 6mm screws, washers (QTY 2)

Lens and Imager Information

	Multispectral	Panchromatic
Pixel size	3.45 μm	3.45 μm
Resolution	1456 x 1088 (1.58 MP per multispectral band)	2464 x 2056 (5.1MP panchromatic band)
Aspect ratio	4 : 3	6 : 5
Sensor size	6.3 mm diagonal	11.1 mm diagonal
Focal length	5.5 mm	10.3 mm
Field of view	49.6° HFOV x 38.3° VFOV (Multispectral bands)	44.5° HFOV x 37.7° VFOV (Panchromatic band)
Output bit depth	12-bit	12-bit
GSD @ 120 m (394 ft)	7.7 cm/pixel per multispectral band	3.98 cm/pixel for panchromatic band
GSD @ 60 m (197 ft)	3.85 cm/pixel per multispectral band	1.99 cm/pixel for panchromatic band

Center wavelengths and bandwidth

Name	Center	Bandwidth
Blue	475 nm	32 nm
Green	560 nm	27 nm
Red	668 nm	16 nm
Red edge	717 nm	12 nm
Near infrared	842 nm	57 nm
Panchromatic	634.5 nm	463 nm

Imager/band number and output

1	Blue
2	Green
3	Red
4	NIR
5	Red edge
6	Panchromatic

Measurements and Attachment Points

There are four M3 screw holes at 60 mm x 35 mm on-center. The sensor can be attached to the host aircraft using at least two of the four provided threaded mounting points and M3 x 0.5 screws. If using only two mounting points, it is important to choose two threaded points opposite of each other.

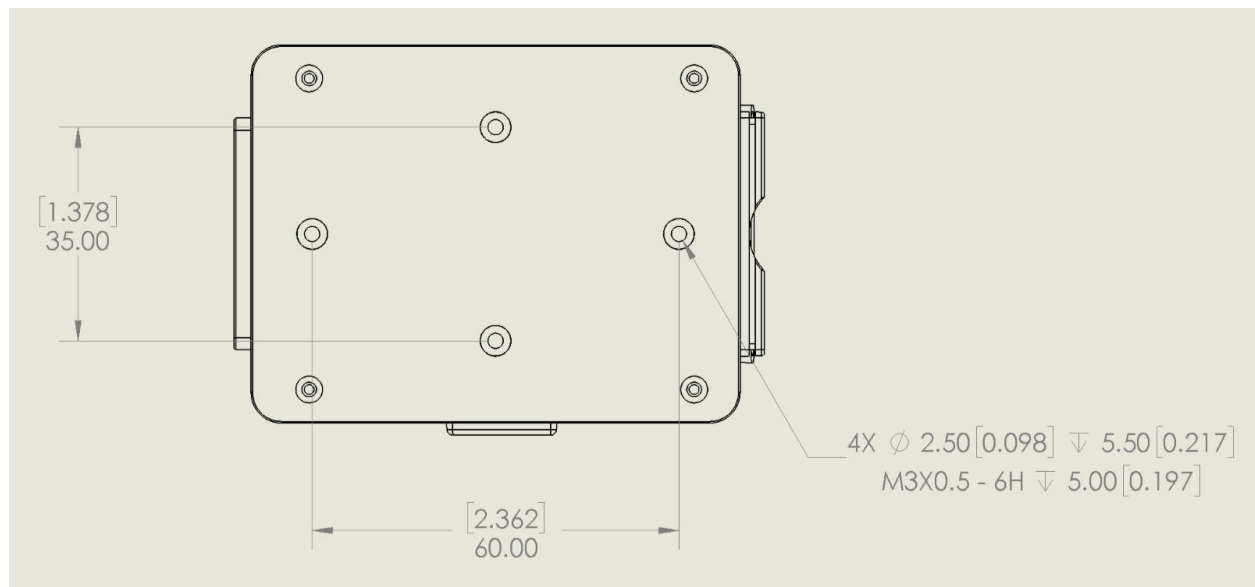

Figure 1

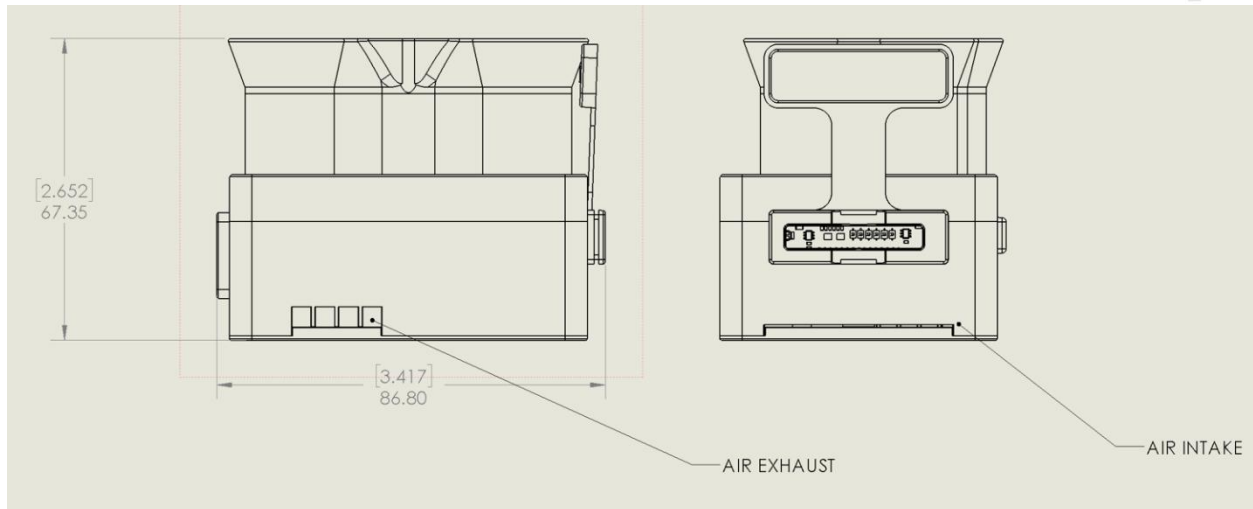

Figure 2

Length	86.8 mm
Width	63 mm
Height	67.35 mm
Mass	245 g (Camera only) 315 g (Camera + DLS 2 + WiFi + Storage)

Recommendations for Installation

The RedEdge-P should be installed such that it has a clear view of the area directly below the aircraft. The “cone” of the lenses, which has the widest field of view (49.6° horizontal, 38.3° vertical), should be considered in the process of deciding where to mount the sensor on the aircraft or payload bay.

The image sensors feature a global shutter and can withstand some vibration without degrading image quality; nevertheless, we recommend vibration isolation between the sensor mounting platform and the aircraft.

Make sure the sensor points straight down (with respect to the earth) at all times during flight. The best way to ensure this is to use a gimbal.

Normally, the sensor should be in landscape orientation. If the sensor is mounted in portrait orientation, remember to swap the vertical and horizontal parameters in the mission planner.

Ensure that the sensor is completely protected during landing. Note that we do not recommend using a glass or transparent lens cover during flight as it can filter the wavelengths that the sensor measures. Instead, protect the sensor with a recessed installation or by using landing gear.

Use the provided rubber lens cover when storing the camera.

Heat/thermal

RedEdge-P has a built-in thermal solution that will notify via the camera's web user interface or light code of a faulty fan that is not spinning. The fan is behind the thin grey backplate and is user serviceable. The thermal solution is completely isolated from the internals of the rest of the camera system

RedEdge-P can draw over 10W peak at full capture rate. The thermal solution must have air exchange and must not be operated in a stagnant environment. For best performance it is recommended to duct some air vanes from the external payload to keep the device at optimal temperature. There is an inlet and exhaust port, and both should be unobstructed. See Figure 2 for the locations of these ports. If flying on a multirotor aircraft, forward aircraft motion helps cool the device sufficiently.

Input and Output



Figure 3

The RedEdge-P and DLS 2 sensor kit includes all necessary cables for integration. If extending the cables, ensure that the voltage at the camera is at acceptable levels as outlined in the “Powering” section of this guide.

The RedEdge-P camera features 3 connectors for interfacing with peripherals and the host aircraft. A fourth connector (USB Type A) is used for the included Wi-Fi module.

External Power (“PWR”)

Power supply specifications

RedEdge-P requires 7.0 V DC for operation, with a maximum operating voltage of 25.2 V. The supply must be able to provide 10 W peak. Power can be provided to the sensor in two main ways:

- shared power from aircraft's main battery pack
- a rechargeable Lithium-Ion battery pack (2S or 3S LiPo will provide optimal efficiency).

Ensure the power source conforms to the specifications listed above and can supply the required voltage at the power port of the camera, accounting for any losses in the wiring.

Note: Pin order is from left to right when the clip is on the top. See Figure 3 for clarification.

Pin #	Signal
1	Power
2	Power
3	Ground
4	Ground
Connectors	
Connector on Camera	JST-GH BM04B-GHS-TBT
Mating Connector	JST-GH GHR-04V-S 28AWG wire recommended

Power Input

Input Voltage Range	7.0 V - 25.2 V
Anticipated power draw	7W continuous, peak 10 W

The RedEdge-P contains under-voltage and over-voltage protection circuitry which nominally applies at 6.8 V and 25.2 V. However, over the operating temperature range these cutoff

voltages can vary by up to 0.2V. For reliable operation, ensure the supply voltage always remains within the operating input voltage range over the full range of operating conditions.

CAUTION

Care should be taken when multiple “grounds” are used for power and trigger of the camera. Only one ground should be connected to the camera – typically this is the ground that corresponds to the source of the power. If the ground of the trigger signal and the ground of the power source are different, they should not be joined together electrically at the camera. In this case, an opto-isolator is recommended to isolate the two grounds that are created by the two separate power systems on the drone.

Please note that RedEdge-P has 2 pins for power, and 2 pins for ground, that are joined electrically at the camera.

Contact support@micasense.com if further information is needed.

DLS connector

The downwelling light sensor (DLS 2) described in more detail later in this document.

Pin #	Signal	Direction
1	5.0 V DC Output	Output From Camera
2	DLS 2/GPS RX	Output From Camera
3	DLS 2/GPS TX	Input To Camera
4	GPS IO 0	Input To Camera/Output from Camera
5	GPS IO 1	Input To Camera/Output from Camera
6	Ground	Ground
Connectors		
Connector on Camera	BM06B-GHS-TBT	
Mating Connector	JST-GH GHR-06V-S 28AWG wire recommended	

Serial and Ethernet Data (“COMM”)

This connector is available for tighter integration with host aircraft. It includes a standard TTL-level serial port as well as an Ethernet port. Documentation for the communications protocol is available by contacting MicaSense.

Pin #	Signal	Direction
1	Ethernet TX N 1G (C-)	Input to Camera
2	Ethernet TX P 1G (C+)	Input to Camera
3	Ethernet RX N 1G (D-)	Output from Camera
4	Ethernet RX P 1G (D+)	Output from Camera
5	Ethernet TX N (A-)	Input to Camera
6	Ethernet TX P (A+)	Input to Camera
7	Ethernet RX N (B-)	Output from Camera
8	Ethernet RX P (B+)	Output from Camera
9	Ground	Ground
10	Host button	Input to Camera
11	HOST GPIO 2	Configurable
12	HOST GPIO 1	Configurable
13	HOST GPIO 0	Configurable
14	Serial RX (3.3 V)	Input to Camera
15	Serial TX (3.3 V)	Output from Camera
Connectors		
Connector on Camera	JST-GH BM15B-GHS-TBT	
Mating Connector	JST-GH GHR-15V-S 28AWG wire recommended	

GPIO pins

There are 3 GPIO pins that can be assigned any of the following functions:

- PPS In
- PPS Out
- Trigger signal input
- Center of Frame (CoF) Output signal

IO Pin voltage

Item	Value
Nominal Voltage	3.3 V DC
Voltage Range	0.0 V DC to 5.0 V DC
Absolute Maximum Voltage	5.1 V DC
PWM Trigger Expected Range	1.0 ms to 2.0 ms

Breakout board

A breakout board accessory is being developed to use with the RedEdge-P. This accessory allows the user to perform bench testing more easily. Connecting the camera to the breakout board allows Ethernet, power, and pin access. When the accessory is released this guide will be updated.

The guide continues on the next page.

LED indicators

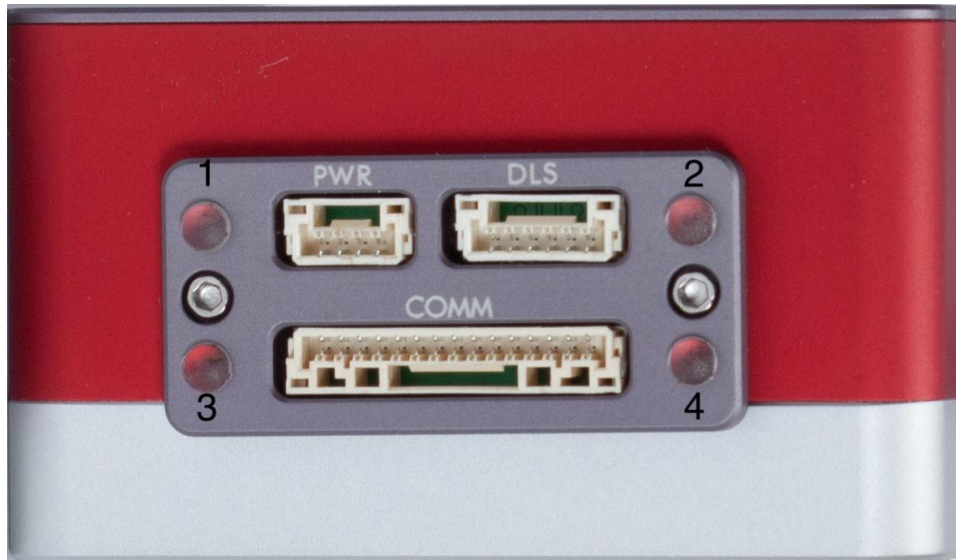

Figure 4

The RedEdge-P has four LEDs around the connectors. During normal operation, they can be interpreted as follows, with the location descriptions assuming the lenses are pointing down:

- Top left light (1) is red: currently this indicator is unused.
- Top right light (2) is blue: there has been a capture
- Bottom left light (3) is green: ethernet link is attached
- Bottom right light (4) is amber, there is ethernet link activity

The meanings of the light patterns on the DLS 2 and on the camera status LED (next to the trigger button) are described in the [MicaSense User Guide](#).

USB port

The RedEdge-P features a USB 2.0 port which supports the Edimax EW-7611ULB Wi-Fi adapter.

Capture Rate

The RedEdge-P capture rate is heavily dependent on the storage device. The RedEdge-P kit includes a CFexpress card which has a maximum capture rate of 3 captures per second (3 Hz). When setting up a mission or flight plan, adjust the desired overlap, flight altitude, and speed so that the capture interval does not exceed the maximum capture rate.

For details on how the sensor writes files to the storage device, see the File Storage section of the [Sensor User Guide](#).

Automatic Capture/Triggering

RedEdge-P supports three methods for capturing images: Overlap, Timer, and External Trigger. To learn more about how to configure these settings, please see the [User Guide for MicaSense Sensors](#).

Overlap (recommended)

In Overlap mode, when the aircraft climbs to within the chosen Target Altitude Tolerance below the Target Altitude, RedEdge-P will start capturing and only take a capture if it has traveled forward enough to ensure the overlap percentage specified. When the sensor's altitude is below the Target Altitude Tolerance from the Target Altitude, the sensor stops capturing. Overlap mode only calculates the forward overlap, and cannot account for the side overlap, which must be calculated in a mission planner, using the sensor's field of view to create an appropriate row spacing.

We recommend this mode because it helps ensure proper overlap (75% or higher), which is essential to produce a high-quality output when processing the data in standard photogrammetry software.

Timer

When in timer mode, RedEdge-P will capture according to the timer period, which is every two seconds by default. If the timer period is set to capture faster than the storage device can write the captures, inconsistent capture intervals may result.

External Triggering

For more control, external trigger mode can be enabled to talk to RedEdge-P by PWM or edge triggering. See the *inputs and outputs* section of this document for detailed pin information.

External Trigger

The sensor can be set to trigger by the rising-edge of a pulse, the falling-edge of a pulse, or a PWM signal (such as is typically used with standard servos). When using a PWM signal as the trigger, the sensor detects a transition from a “long” PWM to a “short” PWM (or vice-versa). When using PWM, rising-edge, or falling-edge, ensure that the input signal’s ground is connected to the isolated ground pin on the camera.

HTTP API (Ethernet and Wi-Fi)

The HTTP API is the most powerful way to interface with the RedEdge-P. This API can be used with either the Ethernet connector or the camera’s Wi-Fi access point.

The API is accessed via HTTP connection to port 80 at the sensor IP address. Most data is exchanged in the JSON format.

The actual value of the IP address depends on the configuration. When accessing the sensor via its Wi-Fi access point, the sensor IP address will be 192.168.10.254. When the sensor is connected to an Ethernet network, the sensor IP address will be 192.168.1.83 by default.

The sensor can be commanded to take a capture by either a GET or POST request to the /capture URL.

The breakout board (see Input and Output section) may be used to interface with the RedEdge-P on the bench with an Ethernet adapter. An Ethernet adapter may also be made by using the information in the “COMM” port section of this guide.

For more information, please see <http://micasense.github.io/rededge-api/api/http.html>

For examples, please see these articles:

- [Integration examples for MicaSense sensors](#)
- [Inputs and outputs for MicaSense sensors](#)
- [How do I communicate with MicaSense sensors?](#)

Serial API

The Serial API provides a MAVLink interface to the RedEdge-P. This API may be used by connecting a MAVLink-capable system to the host serial port on the sensor.

The API is accessed via serial messages in the MAVLink format. MAVLink provides an open data format for interaction as well as a suite of tools to assist the programmer in developing and testing the interface. RedEdge-P uses MAVLink v1.0 messages and communicates with the host at 57600 baud.

For more information and examples, please see <http://micasense.github.io/rededge-api/api/serial.html>

Disabled

“Disabled” should be set when triggering via Skyport (PSDK), HTTP API, or the serial (MAVLink) API. This mode disables the camera’s automatic triggering functions, and will require trigger commands directly from the drone via PSDK, HTTP, or MAVLink, depending on the integration.

The guide continues on the next page.

Configuration Examples

There are many ways to configure the RedEdge-P.

While many other options are possible, the following summaries are intended to help choose the best integration for the user. For more help with integrations, please contact

support@micasense.com

Default + Overlap mode

The default configuration uses the DLS 2's integrated GPS. Use the provided cable to connect the DLS 2 to the camera. Ensure the DLS 2's physical installation meets the requirements outlined later in the DLS 2 section of this guide. Connect a compatible power supply to the camera's power pins. For more details about power, see the Input and Output section of this guide.

Once attached to the aircraft, use the [Flight Calculator](#) to determine the necessary overlap percentage for the desired Ground Sample Distance and Target Altitude, then input the parameters into the Overlap settings, outlined in the Triggering section in this guide. The sensor will begin capturing once it is within the Target Altitude Tolerance of the provided Target Altitude. It will attempt to capture often enough to maintain the desired overlap percentage at the desired altitude. This will ensure enough coverage to create a mosaic of the flight area with photogrammetry software.

Default + Trigger by HTTP API

With this configuration, instead of automatically capturing with an automatic triggering mode, the HTTP API (see below) is used with an onboard computer to trigger the camera at intervals determined by a computer. See examples of the HTTP API here: [Integration examples for MicaSense sensors](#).

MAVLink with PixHawk or similar flight controller

The RedEdge-P can be triggered with a PixHawk or similar flight control system using the serial API. MicaSense cameras currently use the MAVLink v1.0 messaging protocol for the serial API,

which the camera uses to interact with PixHawk. More detailed information can be read here: [Guide for MicaSense Sensors and PixHawk](#).

DLS 2 with Aircraft GPS

For more control, advanced users can communicate with RedEdge-P by HTTP (Ethernet, Wi-Fi) or serial (MAVLink) using the MicaSense APIs (Application Programming Interfaces). The APIs can be used in lieu of the DLS 2 GPS to provide the sensor with a position and attitude data (from the aircraft GPS, for example). Anytime GPS data is sent to the sensor via the API commands, it will be written to the image metadata, overriding the DLS 2 internal GPS data for five seconds (or until another update is sent via the API).

The guide continues on the next page.

Downwelling Light Sensor 2 (DLS 2)

The Downwelling Light Sensor (DLS 2) is an advanced incident light sensor that connects directly to RedEdge-P. During a mission, the DLS 2 measures the ambient light and sun angle and records this information in the metadata of the TIFF images captured by the camera. This information can then be used by specialized processing tools (like Pix4Dmapper and Agisoft Metashape) to correct for global lighting changes in the middle of a flight, such as those that can happen due to clouds covering the sun.

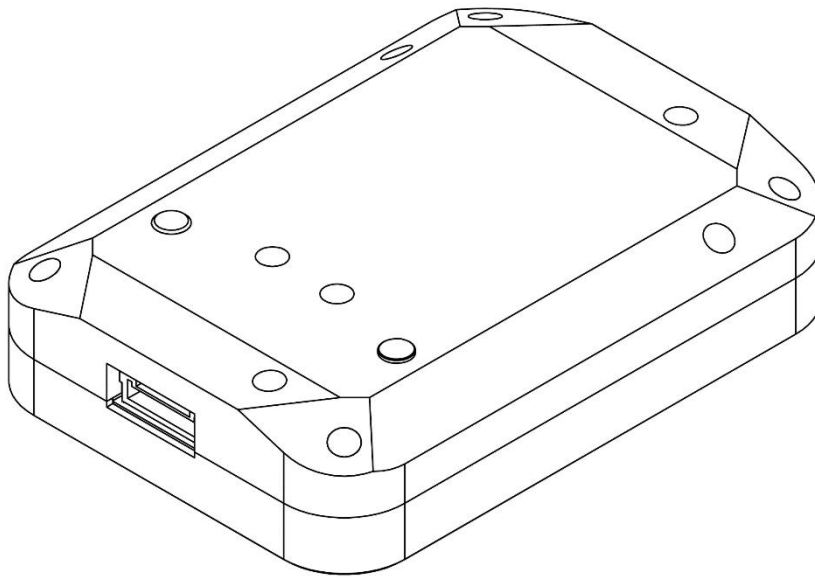

Figure 5

In addition, the DLS 2 provides GPS data to RedEdge-P unless GPS data is provided from an external source as outlined earlier in this guide. If using an alternative GPS source, the GPS receiver will remain on at low power.

Measurements and Attachment Points

Height	14.03 mm
Width	46.00 mm
Length	63.50 mm
Weight	54 g

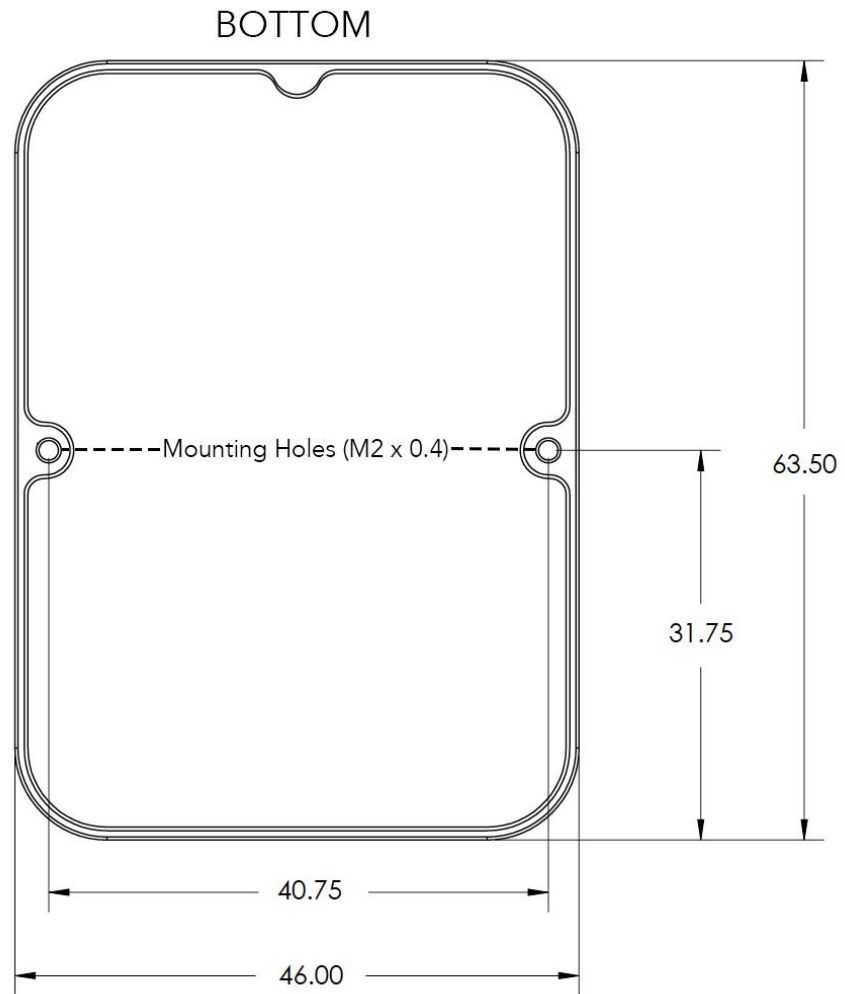

Figure 6

DLS 2 Connectors and Buttons

The sensor kit includes all required interface cables to connect to the DLS 2.

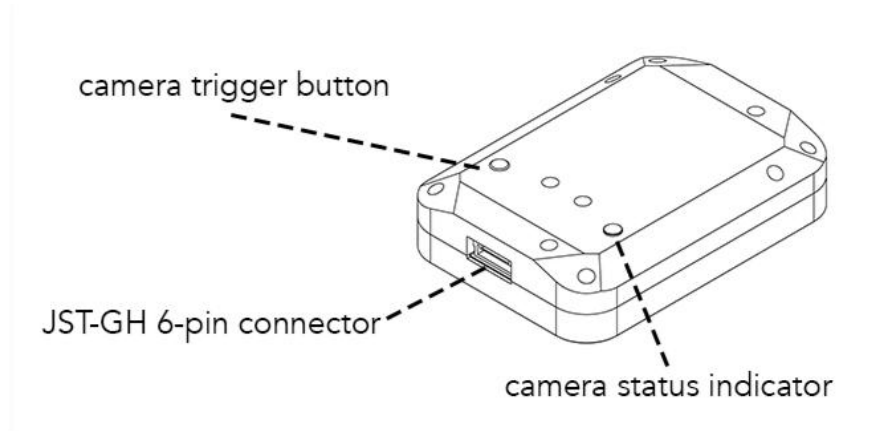

Figure 7

The LED camera status indicator mimics the LED signals on the RedEdge-P. The signal types are outlined in the [User Guide for MicaSense Sensors](#). The camera trigger button will command a capture on the RedEdge-P. This is useful for capturing a preflight image of the calibration panel, but care should be taken not to cover or shade any of the light sensors when pressing the button.

The guide continues on the next page.

DLS 2 Installation Guidelines

The DLS 2 should always be the highest object on the aircraft to avoid shadows or reflections. It contains an integral GPS sensor that may be utilized for geotagging of the RedEdge-P imagery if system GPS signals are not provided to the sensor by other means. Install the module where it will have a clear view of the sky, far away from any devices that could interfere with GPS signals (like a data link or video transmitters).

When the DLS 2 starts up, it attempts to calibrate, which requires it to be still and motionless. Ensure that there is no vibration or movement until the DLS 2 has completed this procedure, indicated by normal LED status lights (shown in the [User Guide for MicaSense Sensors](#)).

NOTE: The 6-pin connector on the DLS 2 should be facing forward, in the flight direction. Mounting it in the opposite direction will cause the magnetometer calibration *process* to be backwards but will otherwise still work.

Fixed wing

Always install the DLS 2 at the high-point of the fuselage (if possible) to avoid any shadowing or reflections from the aircraft fuselage, tail, or propellers.

Do not recess or embed the DLS 2 sensor body below the metallic base.

Local reflections could impact light sensor measurements. Avoid bright or metallic paint near the DLS 2 light sensor as this may interfere with incoming light values.

Secure all wires and harnesses from obstruction with any moving parts including propellers

Multicopter

Install the DLS 2 on a rigid post such that it is the highest object on the aircraft.

Ensure that there are no obstructions in the DLS 2's field of view to the sky, including propellers and other items on the aircraft.

Keep the DLS 2 away from the aircraft GPS. Installing the DLS 2 near the aircraft GPS may impact the aircraft's GPS reception. Secure all wires and harnesses from obstruction with any moving parts including propellers

Example integration photo



RedEdge-P and DLS 2 on a Matrice 300. The sensor draws power directly from the Matrice via the Skyport.
The DLS 2 is the highest object on the aircraft.

MicaSense RedEdge-P and DLS 2 Integration Guide

Revision 01

December 2021

MSPN 900-00028

MicaSense, Inc.

Seattle WA 98103

- The contents of this guide are subject to change without notice
- MicaSense, Inc. assumes no liability for incidental or consequential damages arising from the use of this product, and any claims by a third party.
- Copying of the contents of this guide, in whole or in part is prohibited under the copyright law.

Revision History

Revision	Description	Date
01	Initial release	December 2021