

TK300 Power Supply System

Customer Specification V2.0
2022.11.05

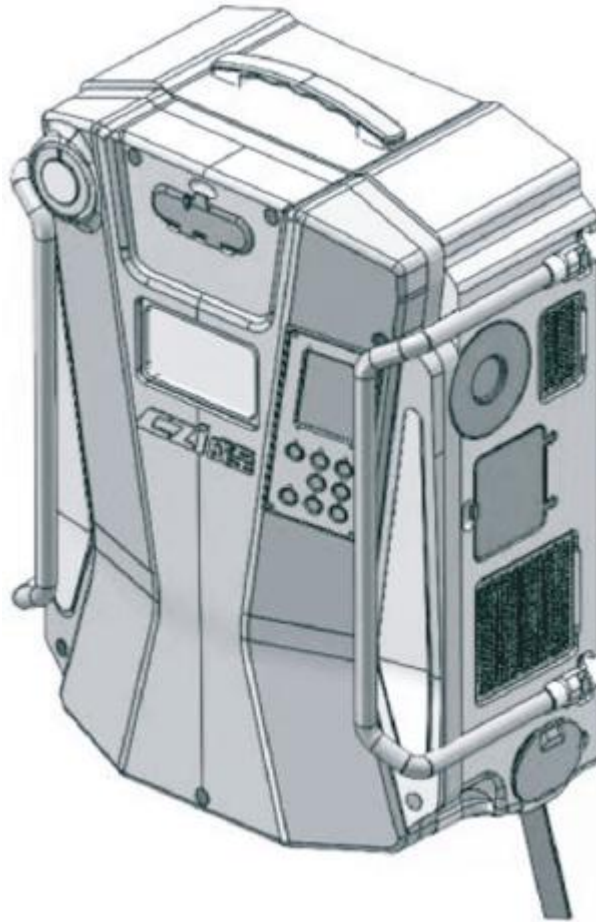

CHENGZHI INTELLIGENCE

Contents

I. Disclaimers and Warnings	1
II. Introduction to TK300 Power Supply System	2
III. Installation and Use Course of TK300 Power Supply System	10
IV. Frequently Asked Questions and Answers When applying TK300 ...	23
V. Firmware Upgrade	26
VI. Product Maintenance and Repair	30

I. Disclaimers and Warnings

Thank you for purchasing our intelligent product. The contents mentioned in this article are related to your safety and legitimate rights and responsibilities, so please read this article carefully to set up the product correctly before using. Harms of hurting you or the people around you or this product or other surrounding items may be caused as a result of failing to follow the instructions and warnings herein. The right for final interpretation of this article and all related documents is vested in CZI. Subject to update without notice. Please visit www.gzczzn.com for the latest product information.

1.1 Warnings

1 Please read the Specification carefully before use to make sure that the TK300 cable is properly connected to the UAV. It's necessary to fix TK300 cable on the UAV tripod with rolled tape or adhesive tape to prevent the rotating blade from hitting the TK300 cable.

2 The battery power of the UAV shall not be less than 80% when in use, otherwise the TK300 will charge it, which will short the battery life.

3 Do not turn on the "power On / Off before the UAV takes off, otherwise the TK300 will charge the battery of the UAV, which will short the battery life.

The correct power-on sequence for the TK300 is to turn on the UAV first and then the TK300 ground end power On / Off.

5 Do not fly in rainy days (because the rain will enter the power box along the mooring line).

6 It's forbidden to touch TK300 cable (high voltage 400V) with any part of your body at any time so as to prevent accidents. If it's necessary, please wear insulating gloves (with high voltage greater than 500V).

II. Introduction to TK300 Power Supply System

The TK300 power supply system is suitable for the M300 RTK UAV, which converts single-phase or three-phase AC into DC high voltage, and transmits the high voltage to the drone power supply through a high-performance nickel alloy power supply cable to continuously power the UAV. It will power the UAV for a continuous 12-hour on a safety basis coordinated with the backup battery.

The TK300 power supply system consists of drone power supply system and ground power supply system, in which the ground power supply system integrates ground power supply, high-performance power supply cable and automatic cable retrieve on and off device. The highly integrated ground power supply system is portable while ensuring quickly executed automatic cable retrieve on and off function, and reducing impacted and bended cable, effective for protecting the cable.

2.1 Drone End Power Supply System

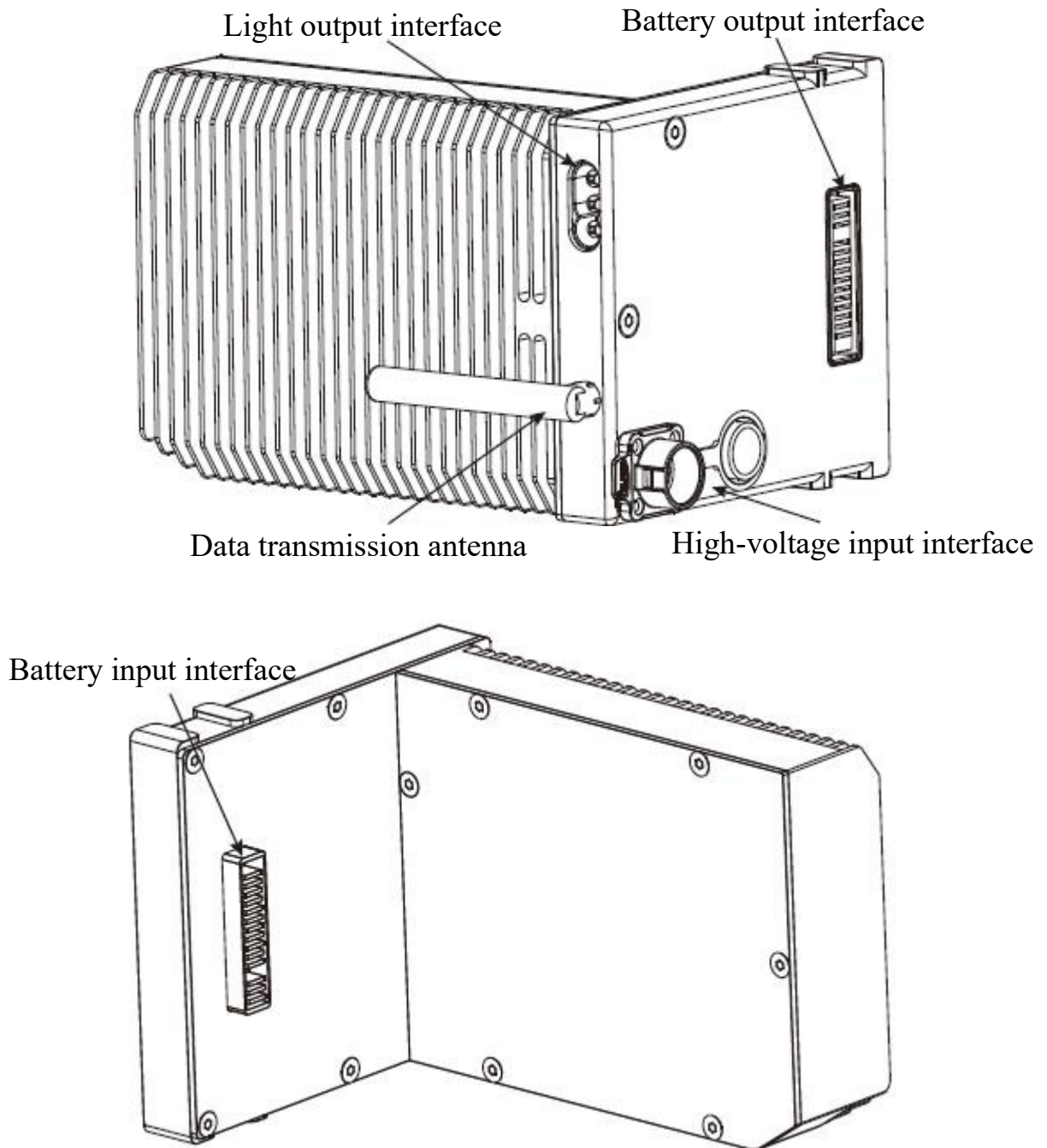

2.2 Ground End Power Supply System

Mode of Transportation

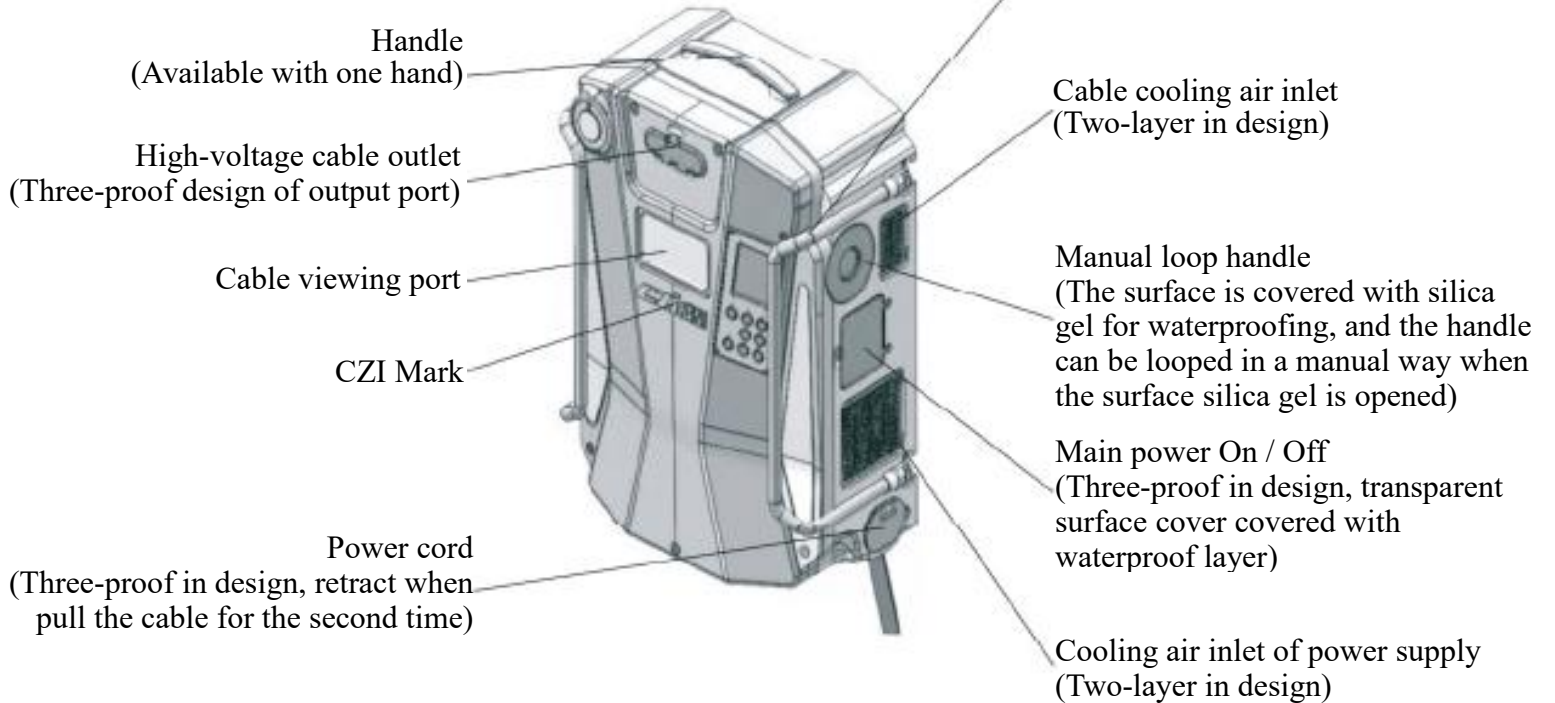

Operating Mode

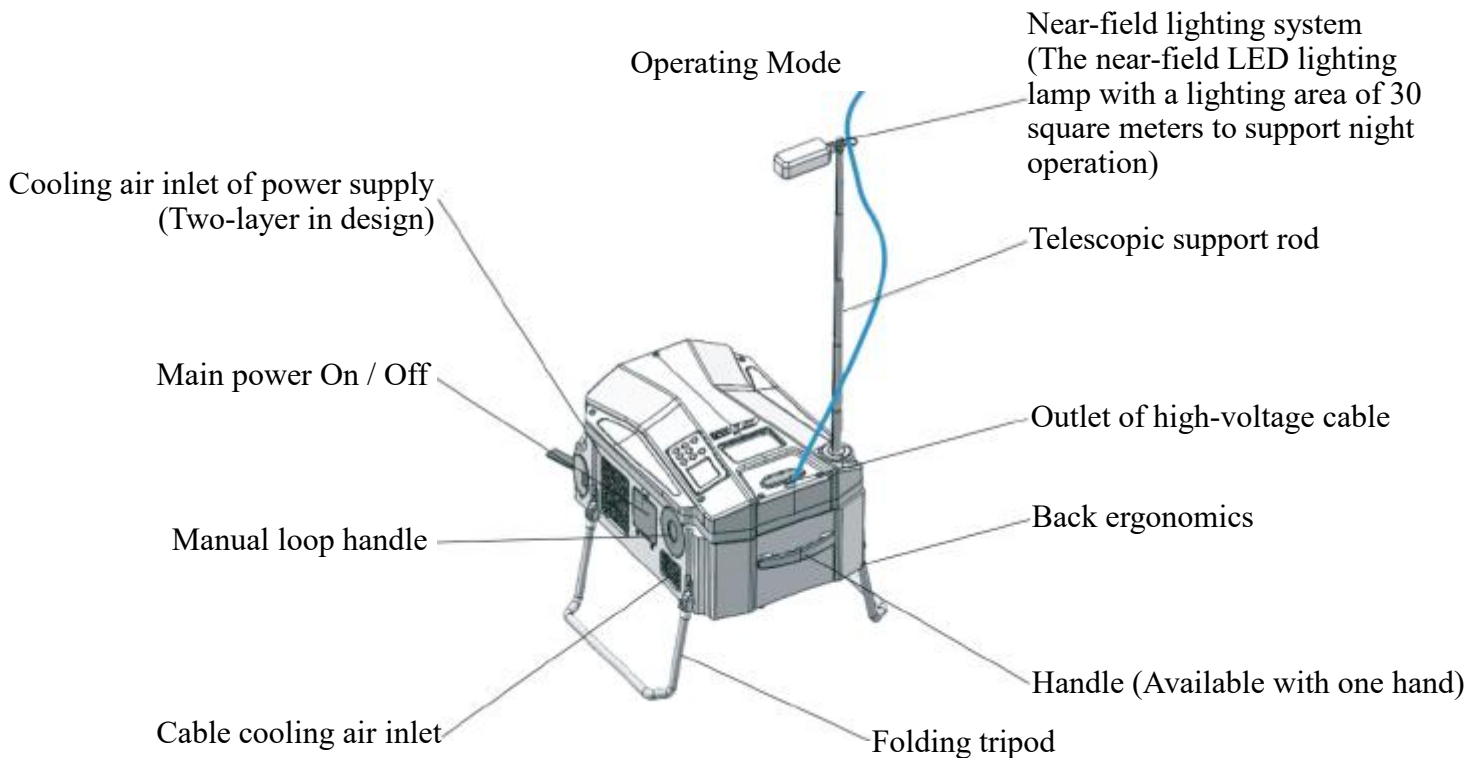

2.3 Ground end power supply system control panel

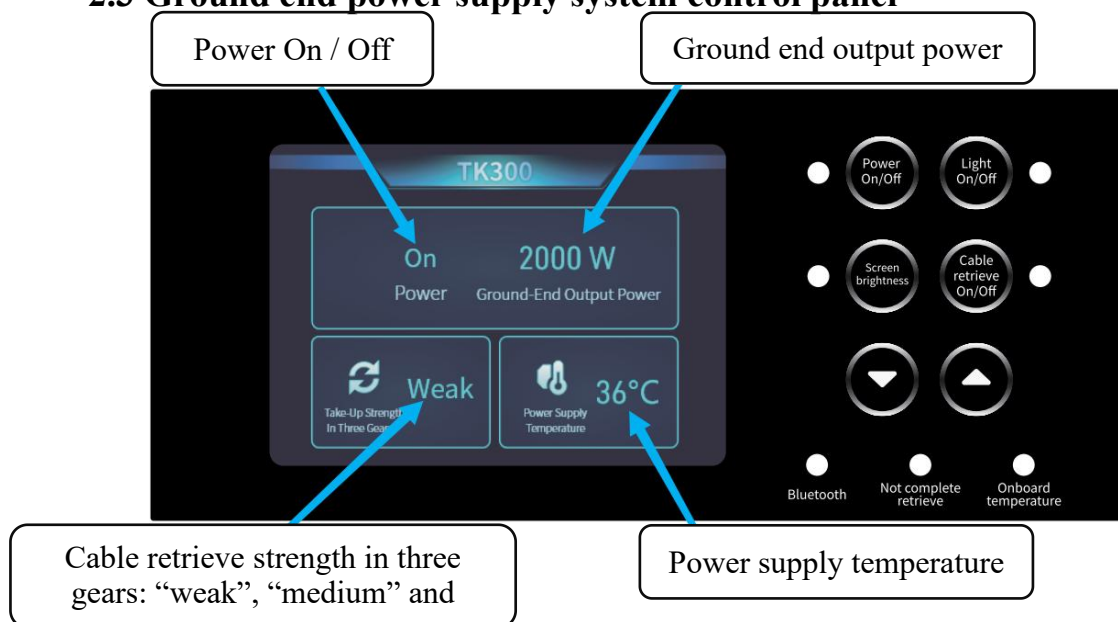

2.3.1 Press the “Power On / Off” for 2 seconds to control the power output on and off (If the green light on the side is on, it means the power is on; if the green light on the side is off, it means the power is off)

2.3.2 Short press the “Light On / Off” to control the turning on and off of the light connected to the drone end

2.3.3. Short press the “Screen Brightness” to switch screen brightness

2.3.4 Short press the “Cable retrieve On / Off” to control the automatic cable retrieve on and off (If the green light on the side is on, it means the cable retrieve is on; if the green light on the side is off, it means the cable retrieve is off)

2.3.5 Short press ▲ to increase cable retrieve strength; short press ▼ to decrease cable retrieve force

2.3.6. When the remote controller is successfully connected to TK300 Bluetooth, the “Bluetooth” indicator light is on green.

2.3.7. When the "remaining cable length" turns green, it means that the length of the remaining cables inside the equipment is sufficient; when the "remaining cable length" turns red, it means that the length of the remaining cables inside the equipment is insufficient. Therefore, it is necessary to observe the length of the remaining cables through the cable observation hole when continuing to fly upward. Please note that the cable length pulled out before the TK300 ground end main power On / Off is turned on shall not exceed 5m, otherwise the "remaining cable length" will not alarm normally. If the TK300 ground end is powered off and restarted during use, the "remaining cable length" will also fail to alarm correctly.

2.3.9. When the “Onboard temperature” turns green, it means that the

drone end can be used normally; when the “Onboard temperature” turns red, it means that the drone end temperature is too high. Please stop using it.

2.4 Equipment Parameters

TK300 drone end power supply	
Overall dimensions	134mm × 92mm × 97mm
Shell material	Aeronautical aluminum alloy
Weight	515 g
Power	Rated 3.0 kw
Rated Input Voltage	280-410 VDC
Rated output voltage	36.5-52.5 VDC
Main rated output current	60 A
Efficiency	95%
Overcurrent protection	When the output current is greater than 65A, the drone power supply automatic protection mode will start.
Overvoltage protection	430 V
Output short circuit protection	Output short-circuit automatic protection, automatically return to normal after troubleshooting
Over-temperature protection function	When the temperature reaches 80°C, the temperature protection mode will start, and the output will be switched off
Control and Interface	Independent control link Aviation waterproof joint Dedicated three-core MR60 light interface

TK300 ground end power supply system	
Overall dimensions	560mm × 390mm × 260mm
Shell color	Grey-black
Flame retardant grade	V1
Weight	13 kg (with cable)
Power	Rated 3.0 kw
Cable	110m cable (80m built-in wire+30m extension wire) with cable diameter less than 3mm, over-current capacity greater than 10A, weight less than 1.2 kg/hundred meter, tensile strength greater than 20 kg, withstand voltage 600V, internal resistance less than 3.6 Ω/100 m@20°C
Rated input voltage	220 VAC+10%
Rated operating frequency	50/60 Hz
Output voltage	280-430 VDC

Requirements for use environment					
Category	Item	Min.	Max.	Unit	Note
Environmental Requirements	Operating temperature (environment)	-20	55	°C	
	Operating temperature (shell temperature)	-20	80	°C	Strong cooling air
	Storage temperature	-40	80	°C	
	Relative humidity	5	95	%	
	Storage humidity	5	95	%	Non-condensing
	Atmospheric pressure	54	106	kPa	Non-condensing
	Altitude	/	3000	m	

III. Installation and Use Course of TK300 Power Supply System

3.1 Installation Tutorial of Drone End Power Supply

3.1.1 Use the matching and dual-purpose battery lock to replace the original M300 battery lock. (No need to be removed after installation)

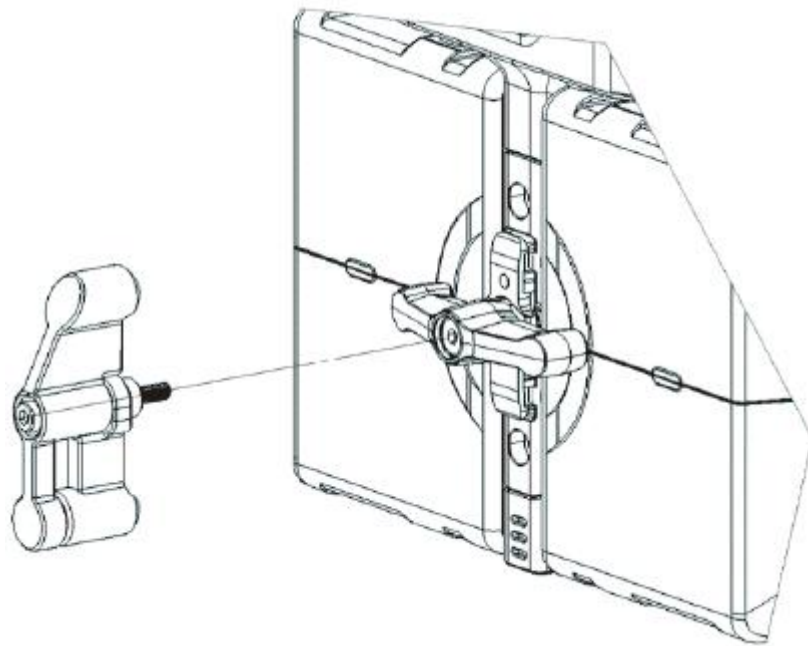

3.1.2 Install the right battery of the M300 aircraft to the onboard power supply. (The electricity of the aircraft battery shall be above 80% when TK300 is used, otherwise the battery may be easily damaged)

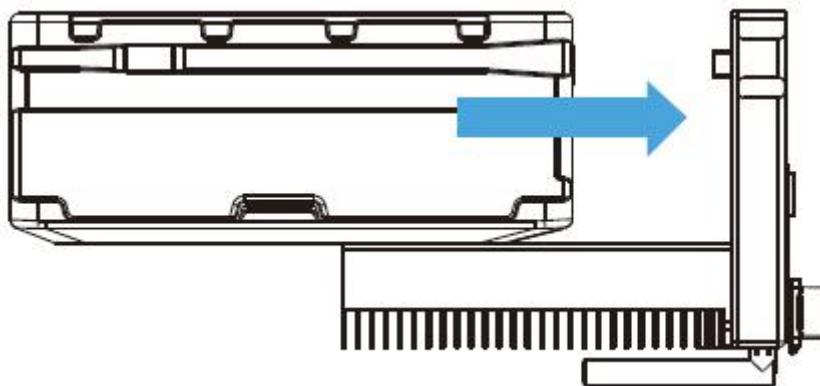

3.1.3 Install the combination of onboard power supply and battery on UAV.

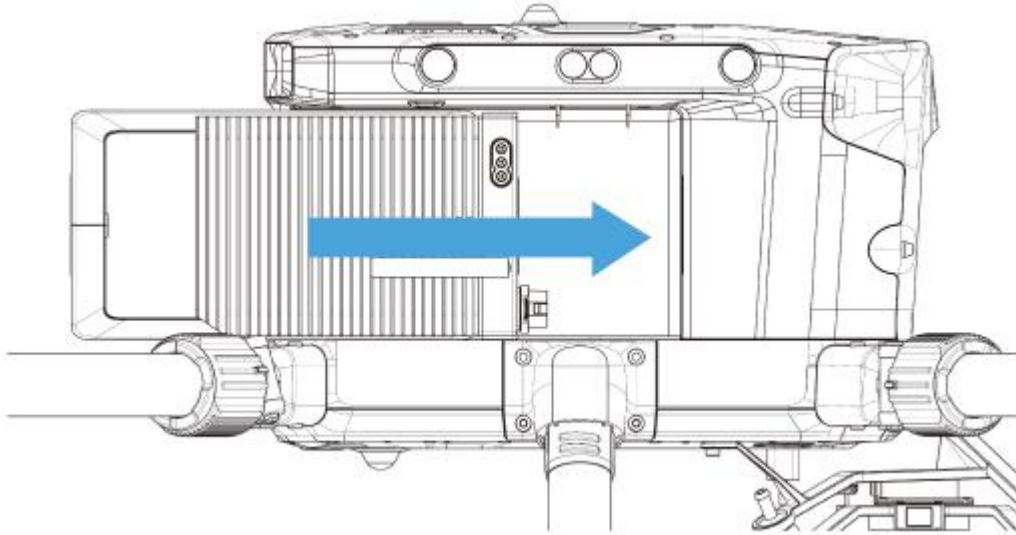

3.1.4 Lock the battery lock of M300 aircraft.

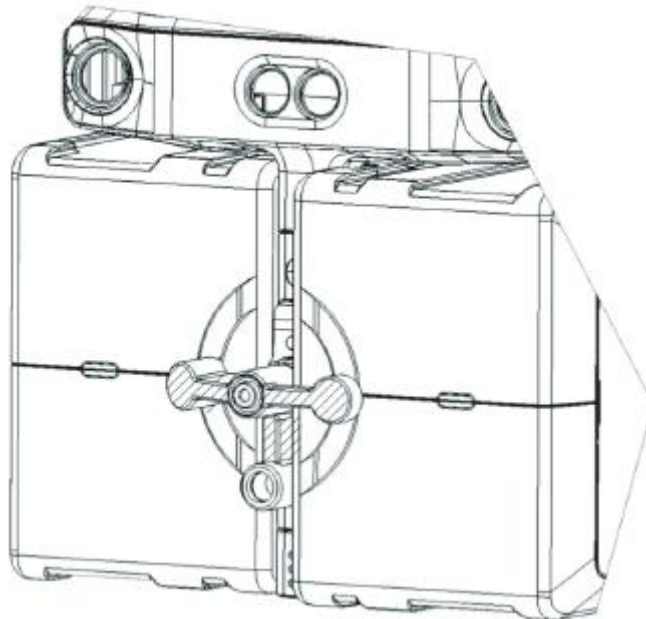

3.2 Installation tutorial of ML150 matrix lamp (Please omitted if ML150 matrix lamp is not used)

Note: The aircraft shall be in a shutdown state when ML150-M300 is being installed. The aircraft can only be started after installation.

3.2.1. Unscrew the hand screws of the matrix lamps, and install the four matrix lamps on the foot of M300, as shown in the figure below:

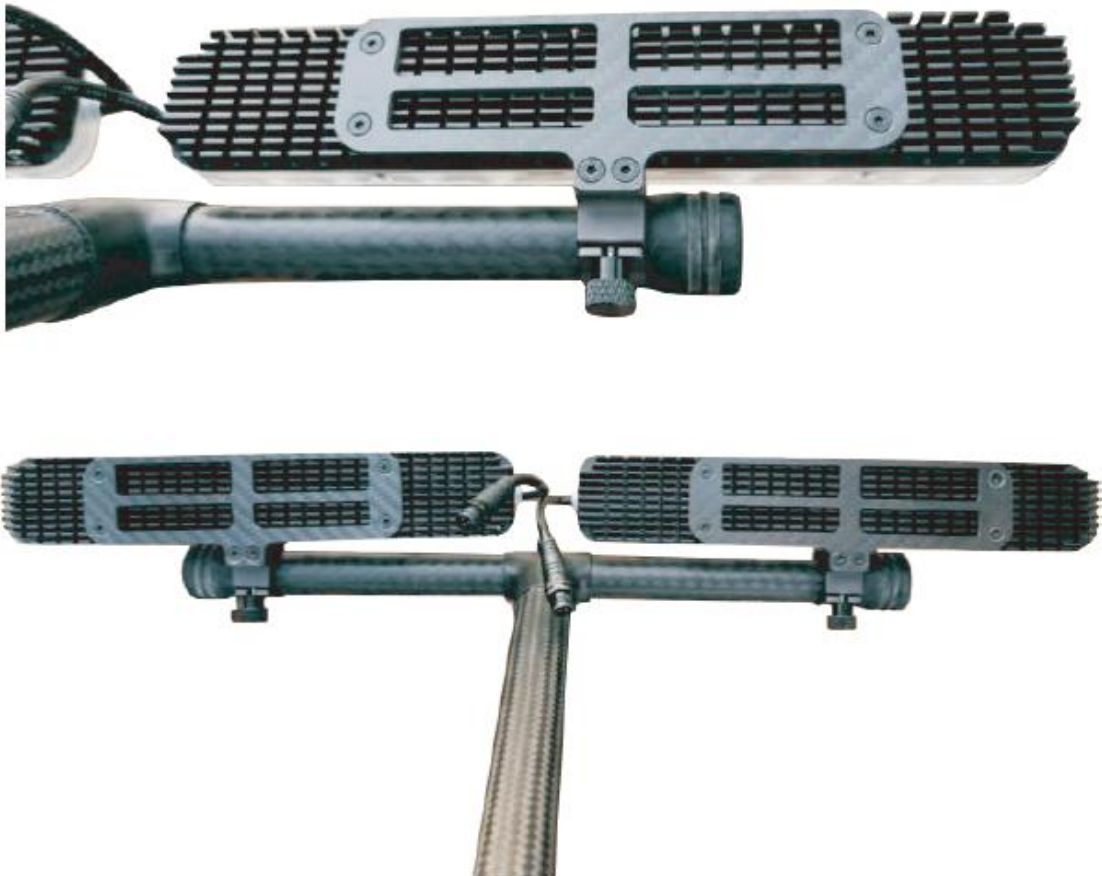

3.2.2. Take out the 4-port wire of ML150-M300, and insert the power plug into the power supply interface at the drone end of TK300 module, as shown in the figure below:



3.2.3. The longer end of 4-port wire passes through the front of the stand, as shown in the figure below:



3.2.4. Connect the connector of lamp with the connector of 4-port wire power supply and tighten it, as the picture show:

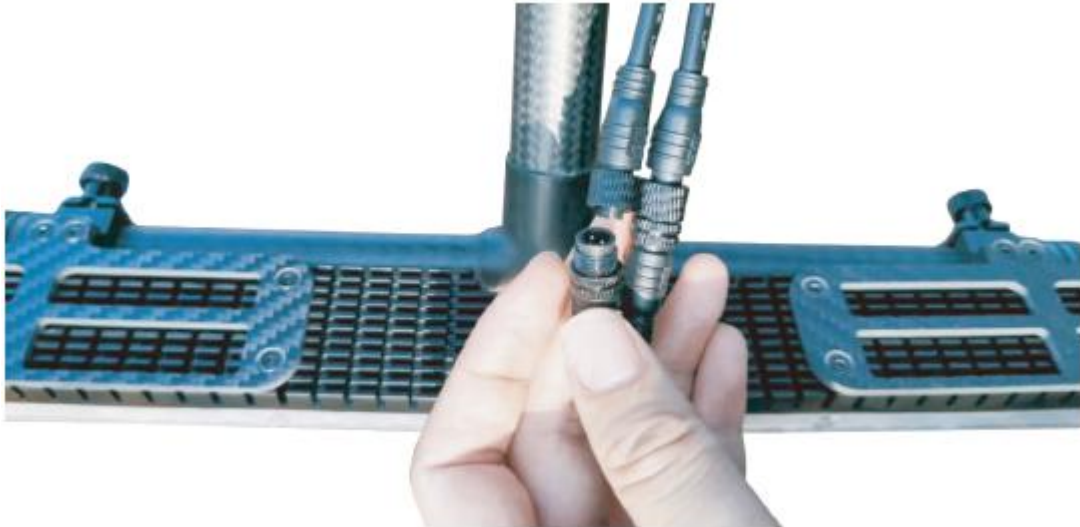

3.2.5. Unfold the magic bandage of a 4-port wire, and use the magic bandage to fasten the wire to the foot of the M300, as shown in the figure below:

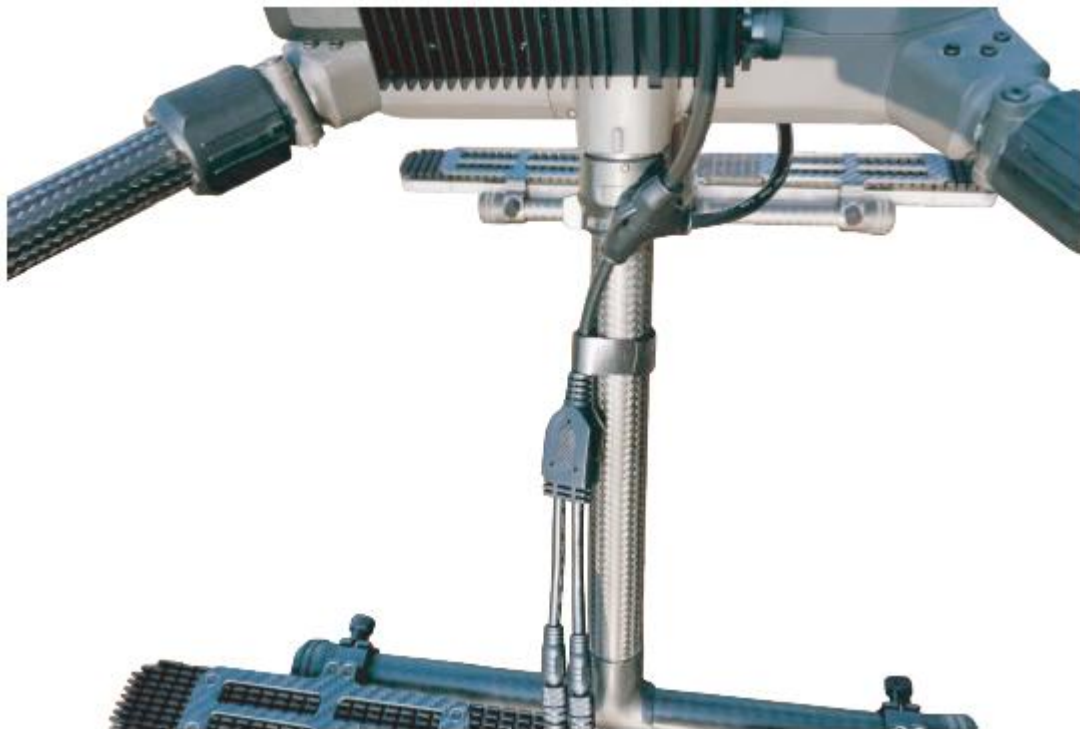

3.2.6. The overall result of installation is as shown in the figure below:



3.3. Installation Tutorial for TK300 Ground end

3.3.1 Unfold TK300 folding stand of ground end and place it horizontally on the ground



3.3.2 Pull out the extendable rod of the TK300 ground end and install the lighting lamp on the top of the extendable rod

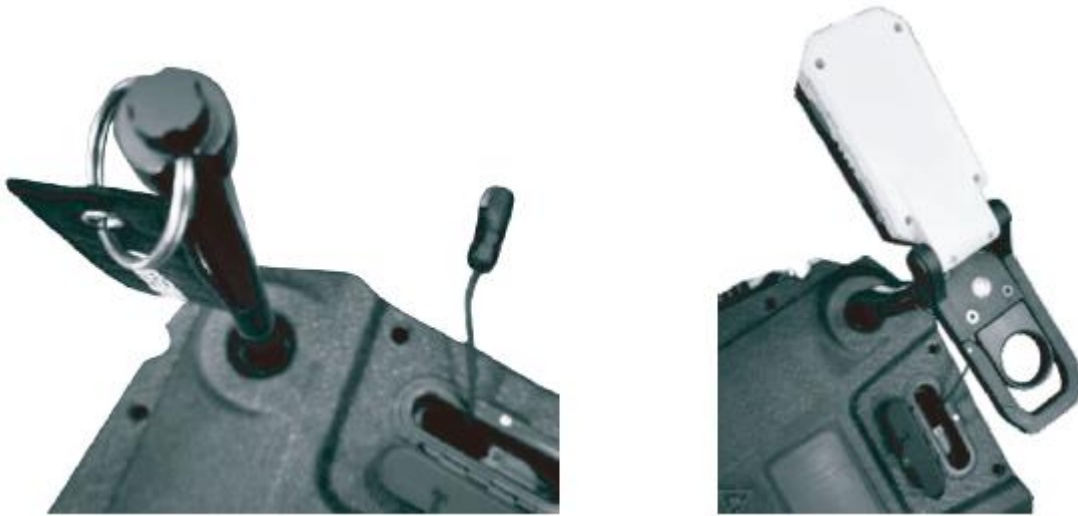

3.3.3 Pull the aviation plug ground end out for about 3m and connect it to the aviation socket of the onboard power supply.



3.3.4 Tie the TK300 power supply line to the foot rest of UAV with magic cable tie. Binding method for single TK300 cable



Binding method for matrix lamp power supply line together



3.3.5 Open the power cover on side of the ground end, pull out the electricity wire to the red label, and connect the connector with the power supply or generator socket



3.4 Tutorial for TK300 Power Supply System

3.4.1 Starting the M300 UAV after installing the TK300 drone end, lighting and TK300 ground end following the above steps.

3.4.2 Turn on the main power On / Off of TK300 ground end and start the ground end.

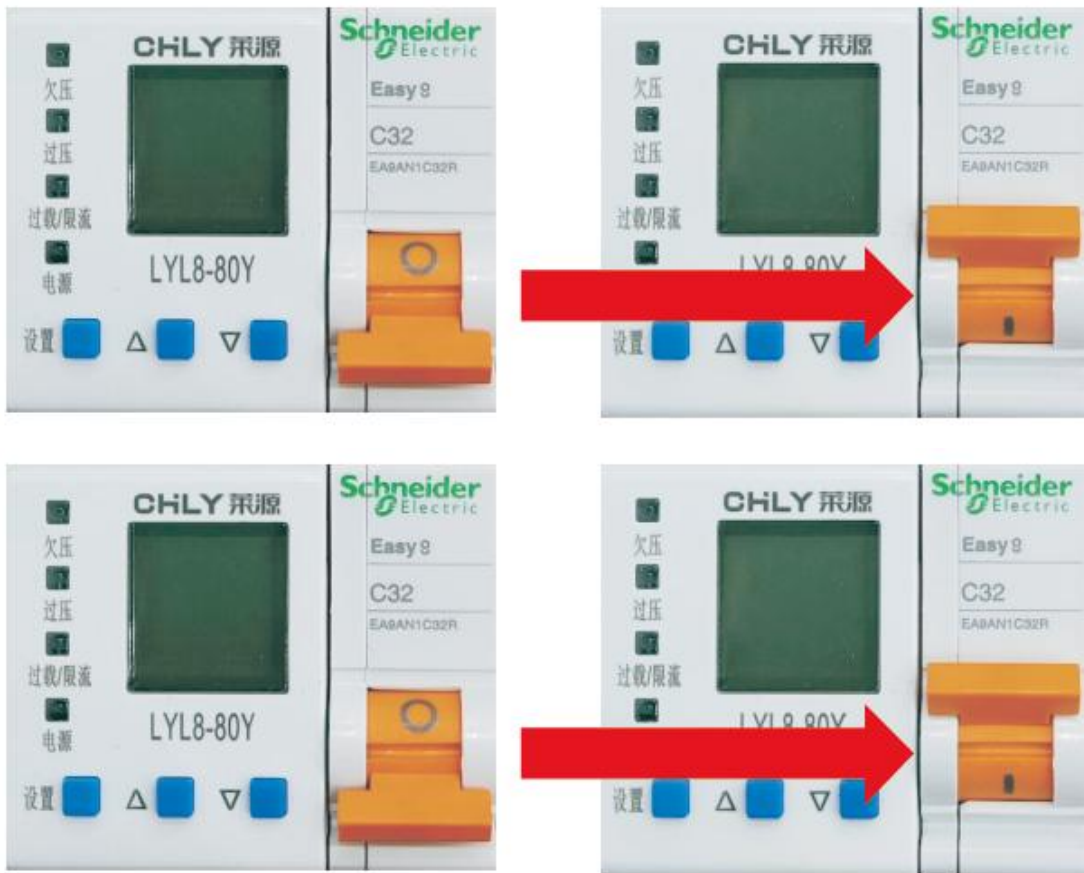

3.4.3 After unlocked, aircraft hover at a height of 3m above the ground.

3.4.4 Press and hold the “Power On / Off” for 2 seconds to start the power output. Please note, do not start the power output before the aircraft takes off, otherwise the battery will be damaged)

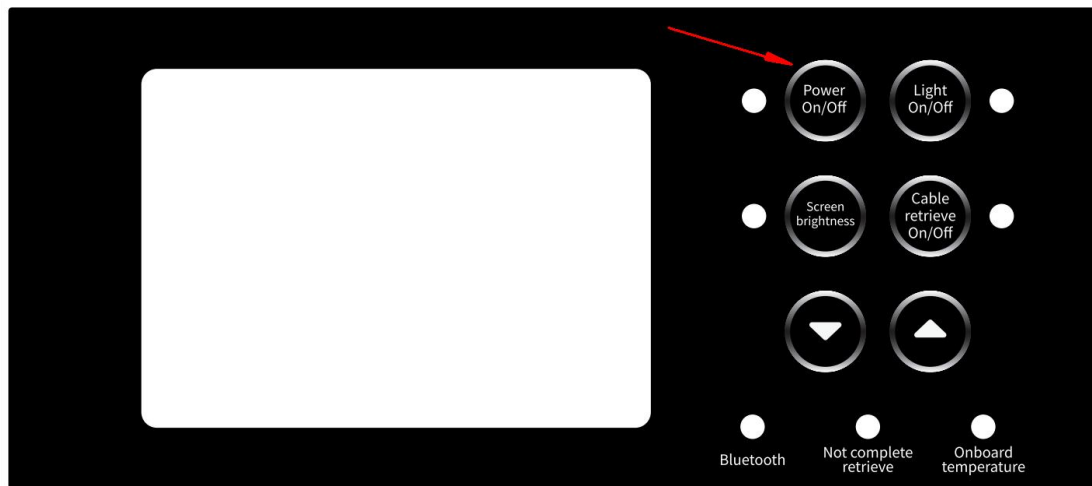

3.4.5 Press “Light On / Off” briefly to turn on the light.

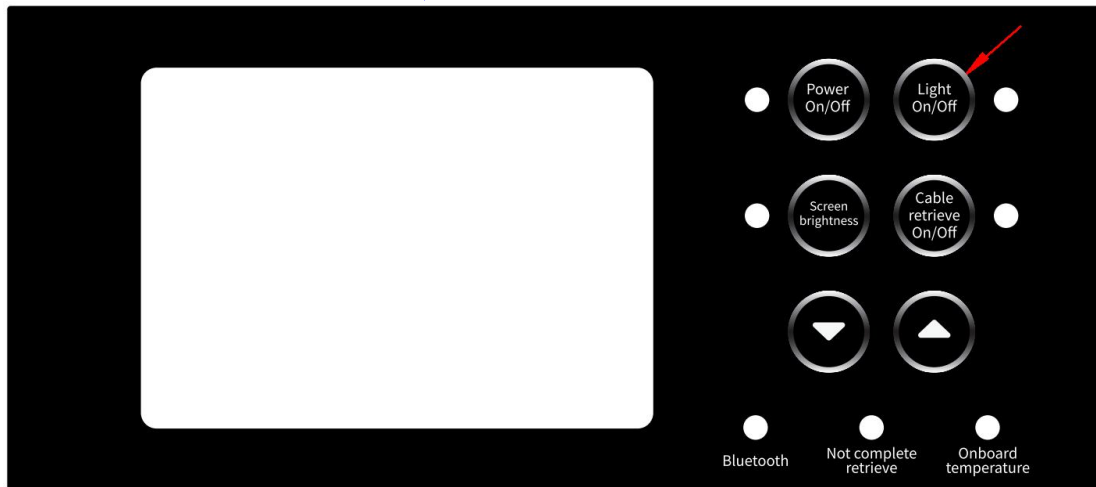

3.4.6 The aircraft ascends at the speed of 1m/s till the predetermined altitude, then hover. Press the “Cable retrieve On / Off” to start the Cable retrieve. Adjust the cable retrieve force as required to straighten the cable.

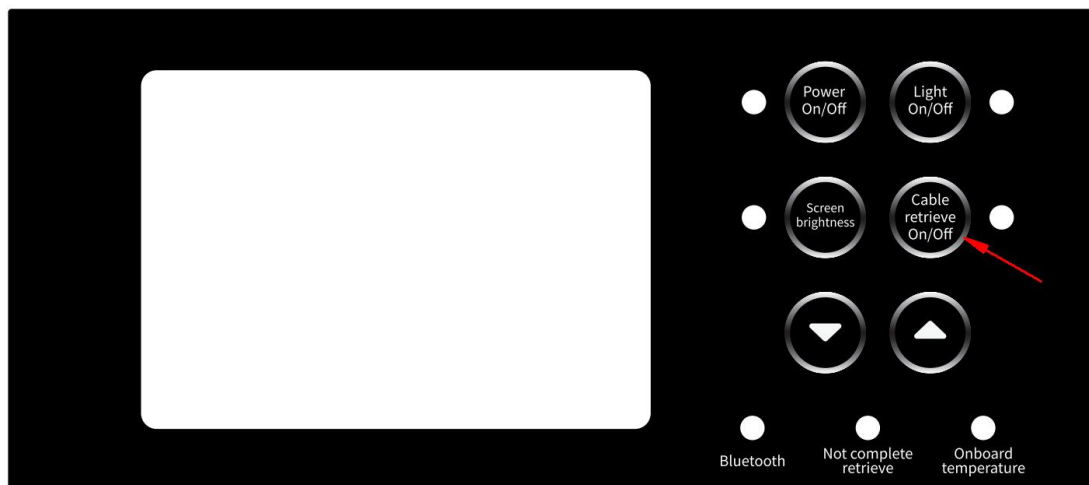

3.5 TK300 Power Supply System Recycling Tutorial

3.5.1. Control UAV to make it descend at a speed of 1 m/s

3.5.2. The UAV descend and hover at a height of 3m above the ground, turn off the lights, close the Cable retrieve and turn off the power output.

3.5.3. Aircraft land on the ground, stop the oars and shut down.

3.5.4 Unplug the aviation plug (please note that the “power on / off” on “off” state is confirmed before pulling out the aviation plug)

3.5.5. Take the remaining power supply cables back into the equipment and turn off the main power switch at TK300 ground end.



3.5.6. Unplug the power supply wire connector from the socket, withdraw the power supply wire and put the power supply cover on 3.5.7. Remove the lighting lamp from the extendable rod and retract the extendable rod.

3.5.8. Make the TK300 ground end stand upright and fold the folding stand.

IV. Frequently Asked Questions and Answers When applying TK300

Question 1: During the use of TK300, the remote controller prompts "The left battery of the battery slot is in poor contact. Please return or land as soon as possible" and "The right battery of the battery slot is in poor contact. Please return or land as soon as possible". What to do?

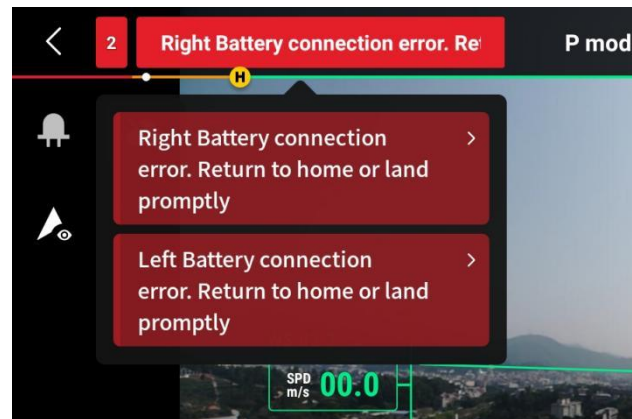

Answer: Normally, the flight can be continued. This alarm will appear when the TK300 is used to power the aircraft. This alarm occurs because when the UAV is in the state of TK300 on working, the TK300 power supply is preferred. When the TK300 power supply can meet the power consumption of the UAV, the battery has no power output, which will trigger the aircraft alarm, it has no impact on flight safety.

Question 2: The UAV fails to take off after TK300 drone end installed. How to deal with it?

Answer: Shut down the UAV, plug and unplug the drone end, and then power it on.

Question 3: Is it normal that the TK300 battery has been slowly powered down during use?

Answer: If the battery is fully charged at the beginning, it will be powered down slowly when it is used, and the output power will rise slowly. When the amount of power and output power reach to a certain number, it will be stabilized. If the battery charge is low at the beginning, the TK300 will slowly charge the battery, which will affect the battery life. Therefore, when using the TK300 products, the battery charge should not be less than 80%. Stable power and stable power are related to carrying equipments, length of power supply cable and other factors.

Please refer to the following table:

Cable length (m)	Carrying equipments	Stable electric quantity (%)	Steady power (W)
80	No-load	78	1050
	Zen H20 Series	78	1190
	GL60 PLUS	76	1325
	Zen H20 series+GL60 PLUS	74	1430
	ML150	74	2020
	Zen H20 series+ML150	72	2070
	GL60 PLUS+ML150	67	2235
110	No-load	66	1080
	Zen H20 Series	65	1220
	GL60 PLUS	64	1360
	Zen H20 series+GL60 PLUS	62	1500
	ML150	56	2080
	Zen H20 series+ML150	52	2450
	GL60 PLUS+ML150	50	2320

Question 4: Can the TK300 power on before starting the power supply for UAV?

A: This is not recommended as it may cause damage to the aircraft's electronic systems.

Question 5: Can a broken wire be handled by myself?

Answer: The damaged wire cannot be handled by yourself. It must be sent back to the manufacturer for treatment.

Question 6: Which interfaces of the TK300 system support hot swap?

Answer: TK300 is a power supply equipment for high voltage. All interfaces do not support hot plug. Remember!

Q7: How much load can the UAV carry when using the TK300?

Answer: The maximum load of DJL M300 is 2.7kg. The weight of the drone end of TK300 is 0.5kg, and the weight of each 100m power supply cable is 1.2kg. If the hovering height is 50m, the weight of the pulled cable is 0.6kg, and the weight of the rest load is $2.5-0.5-0.6=1.6$ kg. The aircraft can't be overweight after a long flight, otherwise it will seriously affect the service life of the aircraft.

V. Firmware Upgrade

5.1. The TK300 ground end is connected with the power supply and the main power On / Off is turned on; the TK300 drone end is installed on the M300, and the M300 unmanned aerial vehicle is turned on (this step is omitted if the drone end does not need to be upgraded); the remote controller is turned on, and the remote controller is connected to the network.

5.2 Enter the main interface of the remote controller, and click the icon in the lower right, as shown in the figure below.

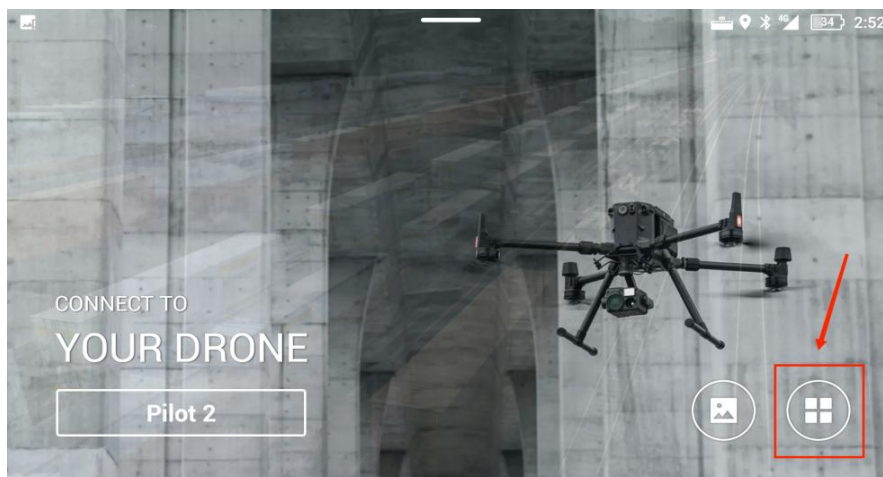

5.3 Open the czi assistant software, as shown in the figure below.

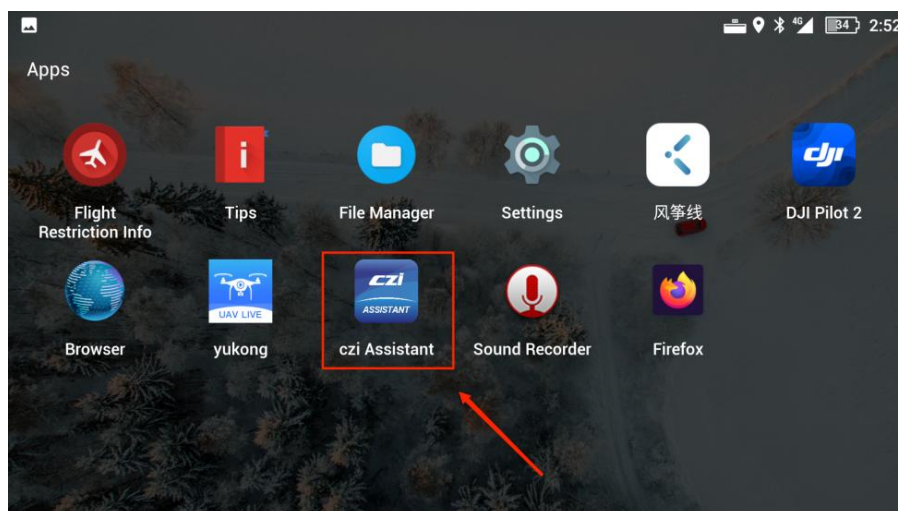

5.4 Click the “≡” icon in the upper right and click “TK300” in the pop-up interface, as shown in the figure below.

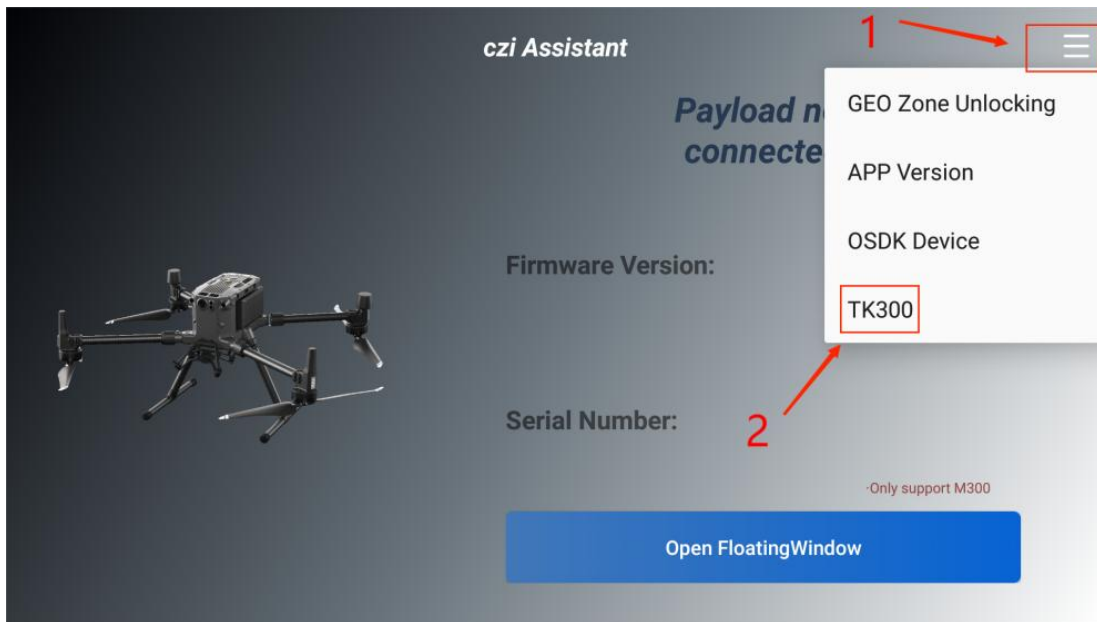

5.5 Click “Connect Device” and click “TK300-XXX.…” in the pop-up interface, as shown in the figure below.

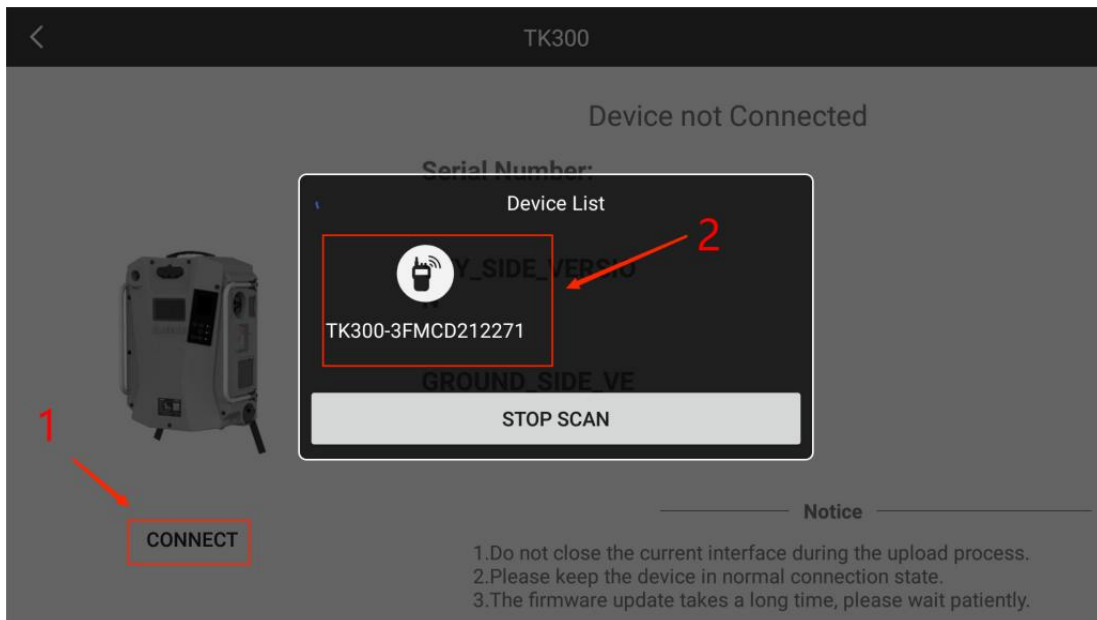

5.6 The drone end updates by clicking the “check version” after “drone end version”, the ground end updates by clicking the “check version” after “ground end version”, as shown in the figure below.

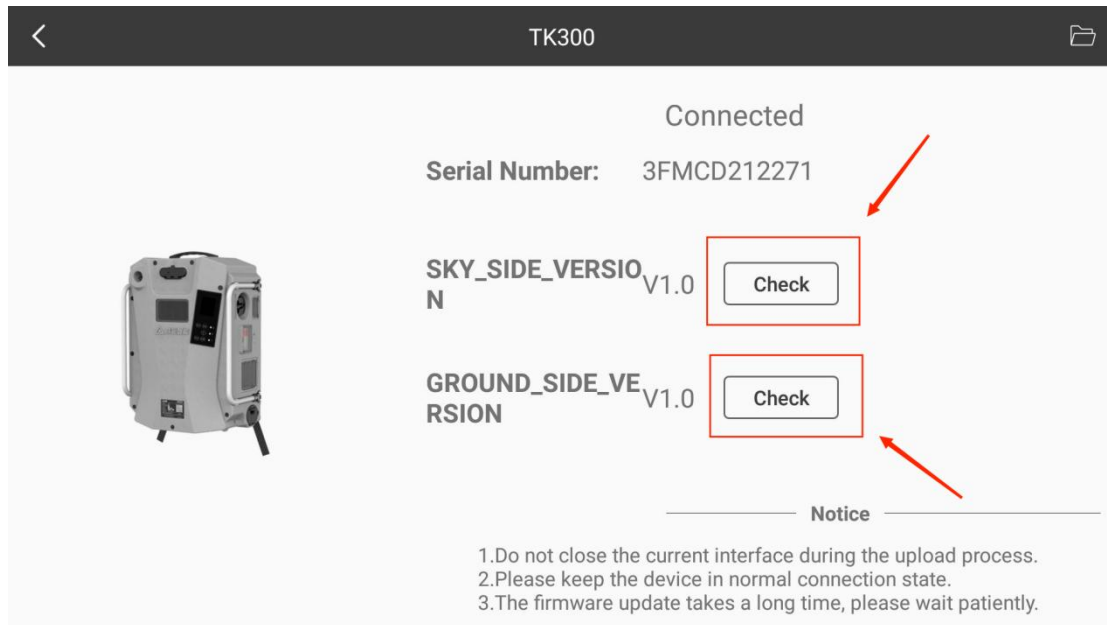

5.7 If a new version is found, click Update Now, as shown in the figure below.

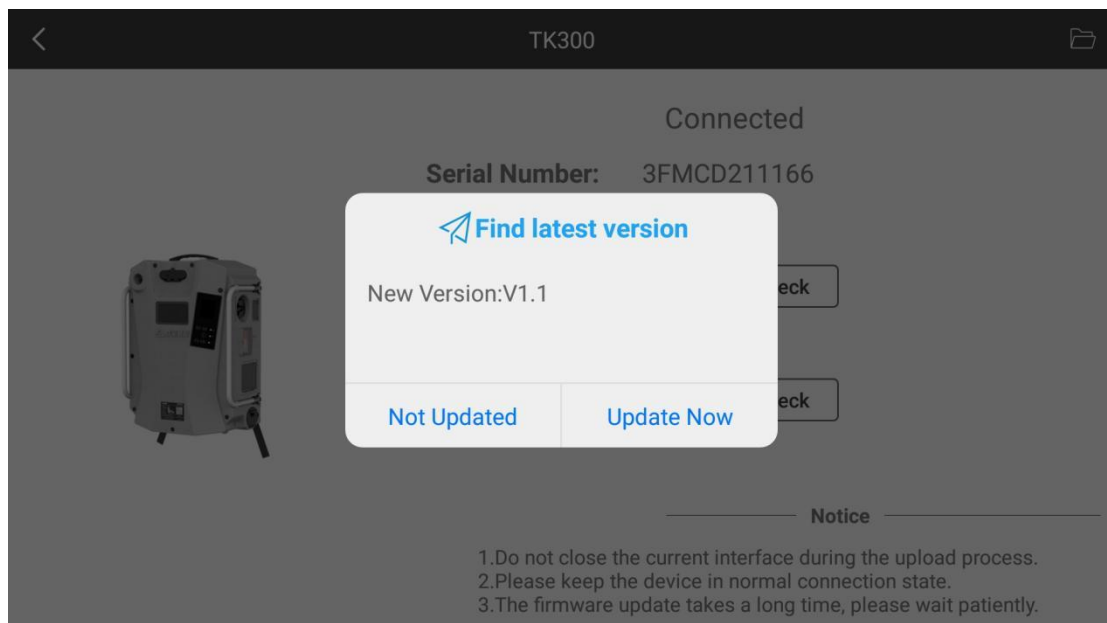

5.8 Wait for the completion of uploading progress, as shown in the figure below.



5.9 Upload succeeds. Click “Confirm”

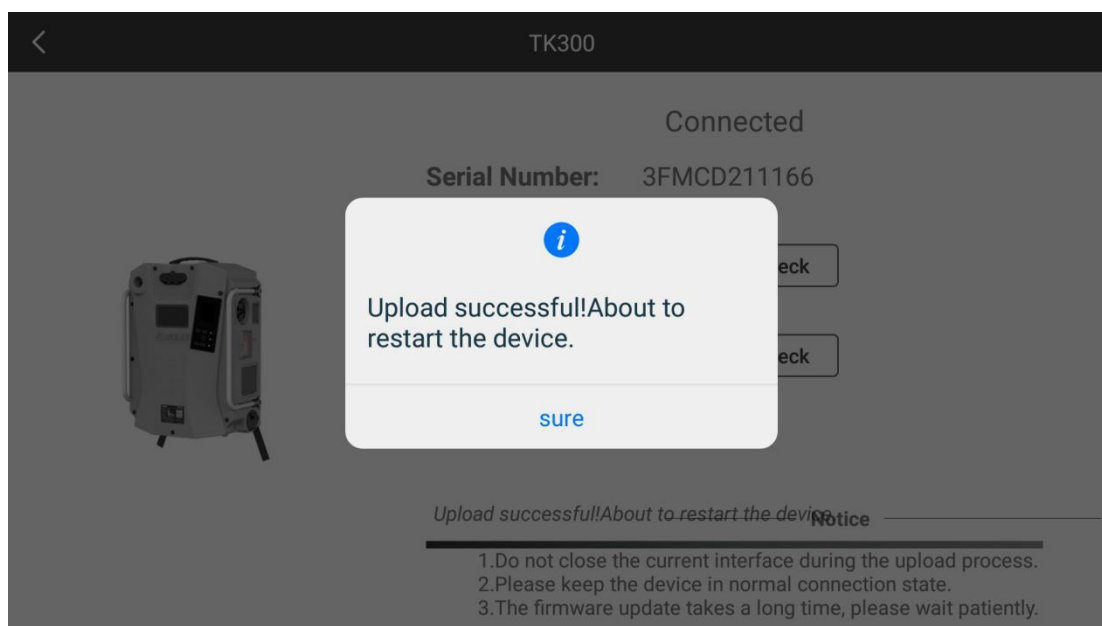

5.10 After the firmware finishing uploading, wait for the ground end display screen to be black and restart, and the upgrade is completed. It takes about 1 minute and 30 seconds for the ground side to upgrade and about 7 minutes for the drone end.

VI. Product Maintenance and Repair

6.1 Inspection and maintenance

Carrying out routine inspection or regular maintenance before and after operation, can greatly improve product reliability, reduce potential safety hazard and extend service life.

6.1.1 Routine inspection

The following routine inspections are recommended before and after each trip.

Power-off check list

Ground end	1. visual and touch to inspect the folding stand, handle, harness and overall housing to see if they are in good condition, cracked or damaged.
	2. Check whether the screws of each connecting part are locked tightly, especially the screws of folding foot rest connecting parts, handle connecting parts and harness connecting parts.
	3. Pull out all TK300 cables and observe whether the surface of the is damaged or adhered. If any damage, they are prohibited to use. Contact the intelligent after-sales. It is strictly prohibited to handle it without permission.
	4. There is no foreign matter blockage behind the air inlet and air outlet of each fan.
	5. Whether the power cord and TK300 power cord can be pulled out normally
Drone end	1. Check whether the front and rear parts are connected tightly and whether the screws are locked.
	2. Check whether the battery locking knob is firm, to ensure that it will not get loose during flight.
	3. Whether there are foreign matters at each interface
	4. Whether there is obvious damage on the surface of drone end. If there is obvious damage, it is prohibited to use for flight.

Inspection of outgoing emergency materials

Ground end	1. One TK300 emergency lamp
	2. More than 2 pairs of magic straps
	3. One outdoor light bag
	4. One rain cover
Drone end (placed in the drone end storage box)	H2.5 Hex Screwdriver
	Insulating gloves

6.1.2 Power-on inspection

- 1 whether the ground end start up normally
- 2 Whether the ground end display screen can display parameters normally
- 3 Flight power supply test: whether the equipment can supply power to the aircraft, and whether ML150 matrix light can be lit normally.
- 4 Whether the ground end can take up normally
- 5 Observe whether each fan can rotate normally

6.2 Product Maintenance

6.2.1 How to Repair

Please call the customer service hotline 400-008-8306 and contact the after-sales for handling if you need to return or replace the goods.

Smart guarantee. Under normal use, the smart products you purchased are free from defects in materials and processes within the warranty period. The warranty period of this product starts from the day of receipt, or CZI specified otherwise.

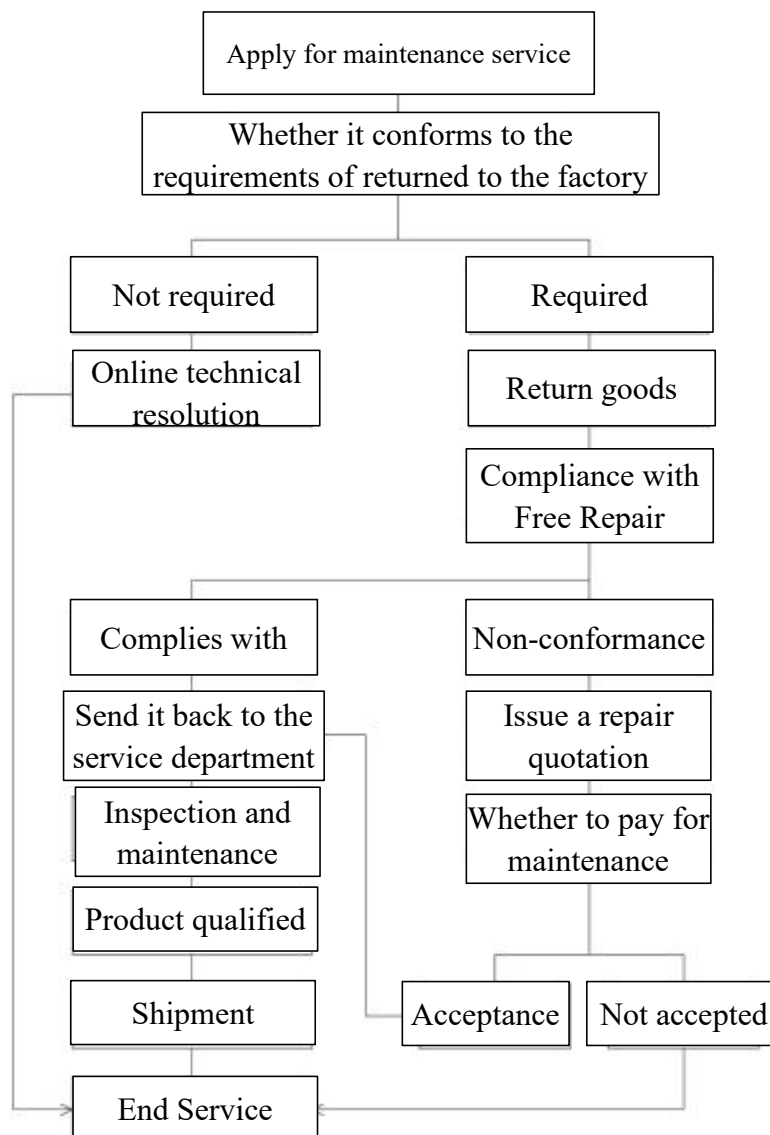

6.2.2 Maintenance rules

In case of any performance failure during the valid warranty period of the product, you may apply for product warranty service. The following conditions must be met for free warranty service:

- ✓ The purchased products are normally used within the specified product warranty period, and non-artificial performance failure occurs;
- ✓ No unauthorized removal, no modification or addition not guided by the official instructions, or other faults not caused by human beings;
- ✓ Provide valid proof of purchase, receipt and order number.

The following conditions are not covered by a free product warranty:

- × Collision and burning accidents caused by man-made and non-product quality problems;
- × Damage caused by unauthorized refitting, disassembly, shell opening, etc. not guided by the official instruction manual;
- × Damage caused by improper installation, use and operation not in accordance with the instruction manual;
- × Damage caused by the customer's self-repair of the assembly without official instructions;
- × Damage caused by circuit modification not guided by official manual or improper matching and use of battery pack and charger;
- × Damage caused by failure to operate not in accordance with the product instructions;
- × Damage caused by operation in severe environment, such as strong wind, rainy day, sand dust, etc.;
- × Damage caused by operation in complex electromagnetic environment or strong interference source environment, such as mining area, launching tower, high-voltage line, substation, etc.;

-
- × Damage caused by manipulation in case of mutual interference with other wireless devices, such as transmitter, image transmission signal, WiFi signal interference, etc.;
 - × Damage caused by forced use in case of aging or damage of parts;
 - × Damage caused by reliability and compatibility when used together with the third-party parts without smart certification;
 - × Damage caused by insufficient discharge due to insufficient power or use of batteries with quality problems;
 - × The serial number of the machine, the factory label and other signs are torn or altered;
 - × After contacting Smart to confirm the warranty service, the corresponding items are not mailed within 7 natural days;
 - × Other situations as stated in the policy.

6.2.3 Other notes:

- √ Due to the differences in products purchased in different countries, returns and warranty services will vary during the warranty period. For more information, please consult 400-008-8306;
- √ When sending the product to czi, you shall bear the postage in advance;
- √ The user shall send the problem product back. After receiving the problem machine, czi Authorized Agent or czi After-sales Service Center shall carry out fault detection on the product to determine the responsibility for the problem. In case of quality defect of the product, czi shall be responsible for the detection cost, material cost, labor cost and express cost;
- √ If the tested product does not meet the conditions for free repair, the customer may choose to pay for repair or mail it back. √ If the problem of the machine is not covered by the warranty (such as man-made damage to the machine), we will charge the corresponding inspection fee, replacement part fee, test fee, labor fee and express fee according to the specific problem;
- √ Please note that product maintenance may result in data loss. Please back up your data first.

-
- √ Data analysis service can be paid to use for the insured products, and the analysis results will not affect czi final processing scheme;
 - √ Please do not send back the seriously damaged batteries such as broken battery core, bump, leakage, etc. If they have been sent back, our company will discard these batteries and do not return them.
 - √ In view of the product version difference, the product does not support global warranty. Warranty service can only be provided in the regional repair center designated by Smart. If the repair is required in the designated repair center in the non-purchased area, czi will handle it as appropriate according to the local inventory situation, and only provide compensable service;
 - √ In case of incorrect address provided by the customer or refusal of the addressee, the customer shall be responsible for the losses arising therefrom;
 - √ If the express delivery cannot be delivered or rejected and returned to czi, czi will take care of it and the storage fee shall be calculated from the date of return. As the storage environment has corresponding requirements, inquiry 400-008-8306 for detail storage fee charge. When the storage fee is equivalent to the residual value of the product, czi will have the right to dispose of the product; (calculation method of product residual value: residual value=original selling price-current maintenance cost)
 - √ If the products are sent back from abroad without the consent of czi, the customs duties and customs clearance expenses arising therefrom shall be borne by the customer;
 - √ In case of water inflow to the product, the performance of the product will be seriously affected, and there is no maintenance value. Therefore, czi cannot provide maintenance service. Instead, The replacement service will be provided.. Please know and send it back as appropriate.
 - √ Before the products are sent for repair, please properly dispose of the personalized articles and decorations attached to the original products (including but not limited to decorative stickers, UAS stickers, paints and lacquers, etc.). czi will not be responsible for the damage or loss of the personalized articles and decorations.
 - √ In order to ensure your normal rights and interests, please check whether the product is in good condition (whether there is any damage caused by logistics) when signing the goods. If the product is abnormal, please feed back to us within 7 days from the date of receipt; otherwise, It's regarded as you agree that the product has no damage and the performance is normal.

CZI Support

www.gzczzn.com

Service hotline: 400-008-8306

If you have any questions or
suggestions about the instructions,

please contact us at

service@gzczzn.com

Printed in China